



INSTYTUT TECHNIKI BUDOWLANEJ



Member of



www.eota.eu

European Technical Assessment

**ETA-24/1085
of 31/01/2025**



General Part

Technical Assessment Body issuing the European Technical Assessment

Instytut Techniki Budowlanej

Trade name of the construction product

FIX-PA, FIX-S, FIX-M, FIX-MT and FIX-W

Product family to which the construction product belongs

Nailed-in and screwed-in plastic anchors for fixing of external thermal insulation composite systems (ETICS)

Manufacturer

ZIEL-PLAST Zielińscy Spółka Komandytowa
ul. Zamkowa 28
32-652 Bulowice
Poland

Manufacturing plant

ZIEL-PLAST Zielińscy Spółka Komandytowa
ul. Zamkowa 28
32-652 Bulowice
Poland

This European Technical Assessment contains

34 pages including 3 Annexes which form an integral part of this Assessment

This European Technical Assessment is issued in accordance with regulation (EU) No 305/2011, on the basis of

European Assessment Document (EAD)
330196-01-0604 "Plastic anchors made of virgin or non-virgin material for fixing of external thermal insulation composite systems with rendering"



This European Technical Assessment is issued by the Technical Assessment Body in its official language. Translations of this European Technical Assessment in other languages shall fully correspond to the original issued document and shall be identified as such.

Communication of this European Technical Assessment, including transmission by electronic means, shall be in full. However, partial reproduction may only be made with the written consent of the issuing Technical Assessment Body. Any partial reproduction has to be identified as such.

Specific Part

1 Technical description of the product

The FIX-PA nailed-in plastic anchor consists of an anchor sleeve with a plate made of polypropylene (virgin material) and an accompanying specific nail as an expansion pin made of glass fibre reinforced polyamide (virgin material).

The FIX-S nailed-in plastic anchor consists of an anchor sleeve with a plate made of polypropylene (virgin material) and an accompanying specific steel nail as an expansion pin.

The FIX-M nailed-in plastic anchor consists of an anchor sleeve with a plate made of polypropylene (virgin material) and an accompanying specific steel nail as an expansion pin.

The FIX-MT screwed-in plastic anchor consists of an anchor sleeve with a plate made of polypropylene (virgin material) and an accompanying specific steel nail as an expansion pin.

The FIX-W nailed-in plastic anchor consists of an anchor sleeve with a plate made of polypropylene (virgin material) and an accompanying specific nail as an expansion pin made of polypropylene (virgin material).

The plastic anchor sleeve is expanded by hammering or screwing an expansion pin, which press the sleeve against the wall of the drilled hole.

The FIX-PA, FIX-S, FIX-M, FIX-MT and FIX-W anchors may in addition be combined with the plastic plates TDW 90, TDW 110, TDW 130 and TDW 110 G.

The description of the products is given in Annex A.

2 Specification of the intended use in accordance with the applicable European Assessment Document (EAD)

The performances given in Annex C are only valid if the anchor is used in compliance with the specifications and conditions given in Annex B.

The provisions made in this European Technical Assessment are based on an assumed working life of the anchor of 25 years. The indications given on the working life cannot be interpreted as a guarantee given by the producer or Technical Assessment Body, but are to be regarded only as a means for choosing the right products in relation to the expected economically reasonable working life of the works.

3 Performance of the product and references to the methods used for its assessment

3.1 Performance of the product

3.1.1 Safety and accessibility in use (BWR 4)

Essential characteristic	Performance
Characteristic resistance	Annex C1
Edge distances and spacings	Annex B2
Plate stiffness	Annex C2
Displacements	Annex C3

3.1.2 Energy economy and heat retention (BWR 6)

Essential characteristic	Performance
Point thermal transmittance	Annex C2

3.2 Methods used for the assessment

The assessment has been made in accordance with EAD 330196-01-0604.

4 Assessment and verification of constancy of performance (AVCP) system applied, with reference to its legal base

According to Decision 97/463/EC of the European Commission the system 2+ of assessment and verification of constancy of performance (see Annex V to regulation (EU) No 305/2011) applies.

5 Technical details necessary for the implementation of the AVCP system, as provided in the applicable European Assessment Document (EAD)

Technical details necessary for the implementation of the AVCP system are laid down in the control plan deposited in Instytut Techniki Budowlanej.

For type testing the results of the tests performed as part of the assessment for the European Technical Assessment shall be used unless there are changes in the production line or plant. In such cases the necessary type testing has to be agreed between Instytut Techniki Budowlanej and the notified body.

Issued in Warsaw on 31/01/2025 by Instytut Techniki Budowlanej

Anna Panek, MSc
Deputy Director of ITB

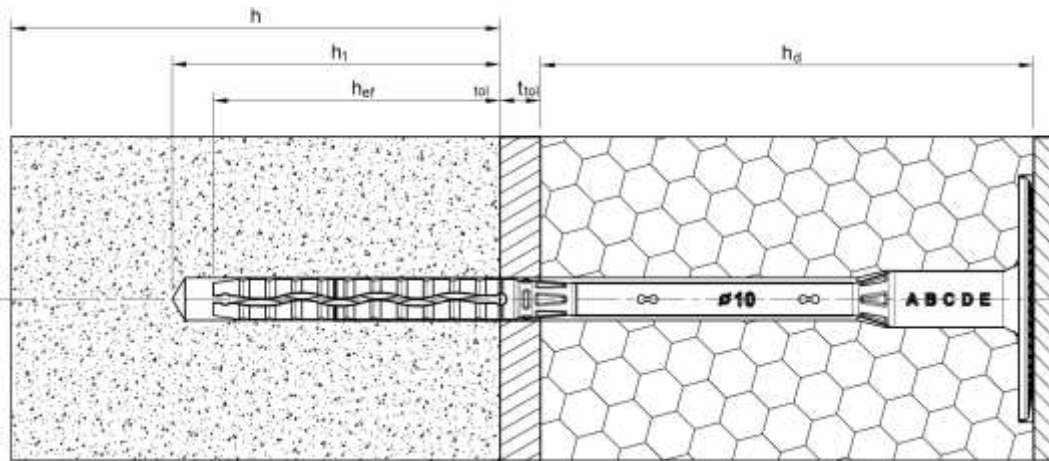
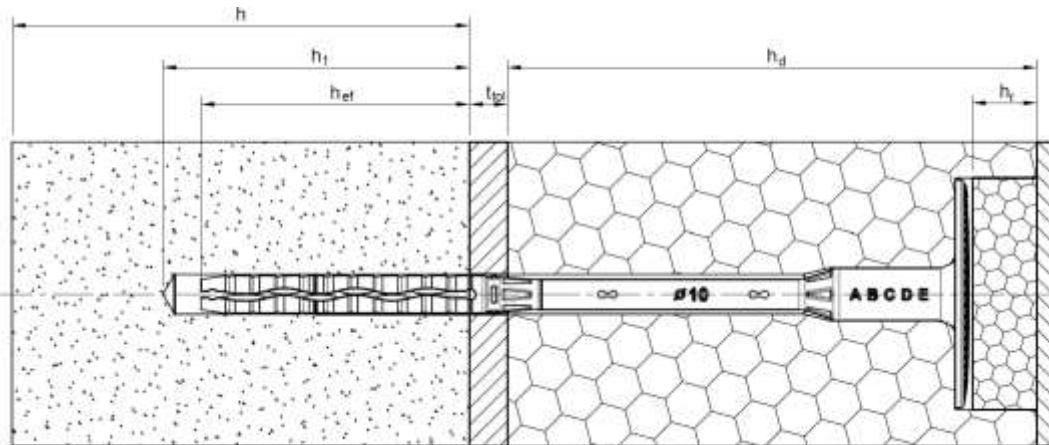
Surface assembly ($h_{ef} = 70$ mm):

Countersunk assembly ($h_{ef} = 70$ mm):

Intended Use:

Fixing of external thermal insulation composite systems (ETICS) in concrete and masonry

Legend:

$h_{nom} = h_{ef}$ = effective anchorage depth

h_1 = depth of drill hole in base material

h = thickness of base material

h_d = thickness of insulation material

h_r = thickness of insulation cap

t_{tol} = thickness of equalizing and/or non-load-bearing layer

FIX-PA, FIX-S, FIX-M, FIX-MT and FIX-W

Product description

Installation conditions with effective anchorage depth 70 mm

Annex A1
of European
Technical Assessment
ETA-24/1085

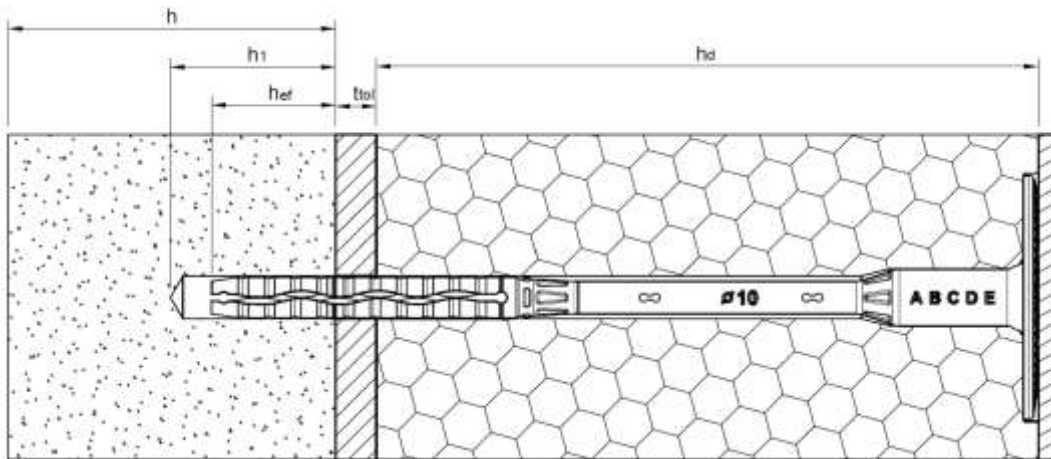
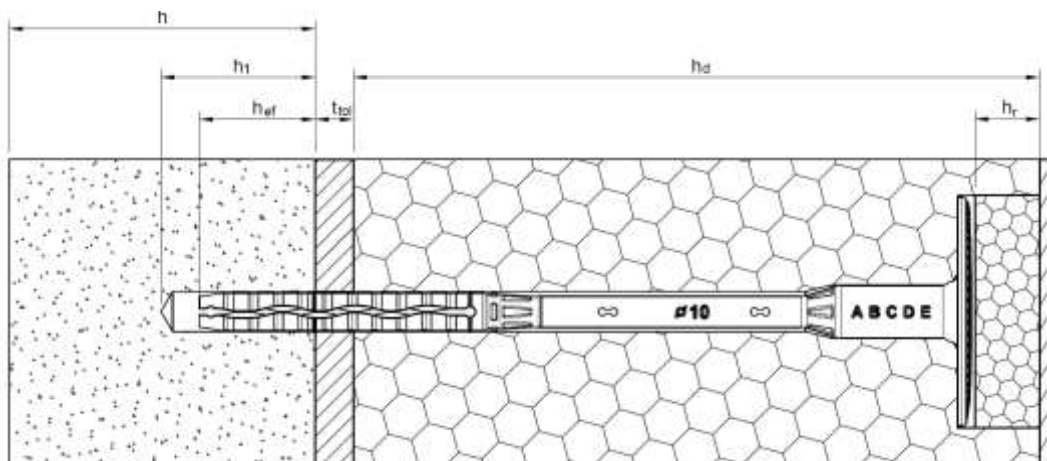
Surface assembly ($h_{ef} = 30$ mm):**Countersunk assembly ($h_{ef} = 30$ mm):****Intended Use:**

Fixing of external thermal insulation composite systems (ETICS) in concrete and masonry

Legend:

$h_{nom} = h_{ef}$ = effective anchorage depth

h_1 = depth of drill hole in base material

h = thickness of base material

h_d = thickness of insulation material

h_r = thickness of insulation cap

t_{tol} = thickness of equalizing and/or non-load-bearing layer

FIX-PA, FIX-S, FIX-M, FIX-MT and FIX-W

Product description

Installation conditions with effective anchorage depth 30 mm

Annex A2
of European
Technical Assessment
ETA-24/1085

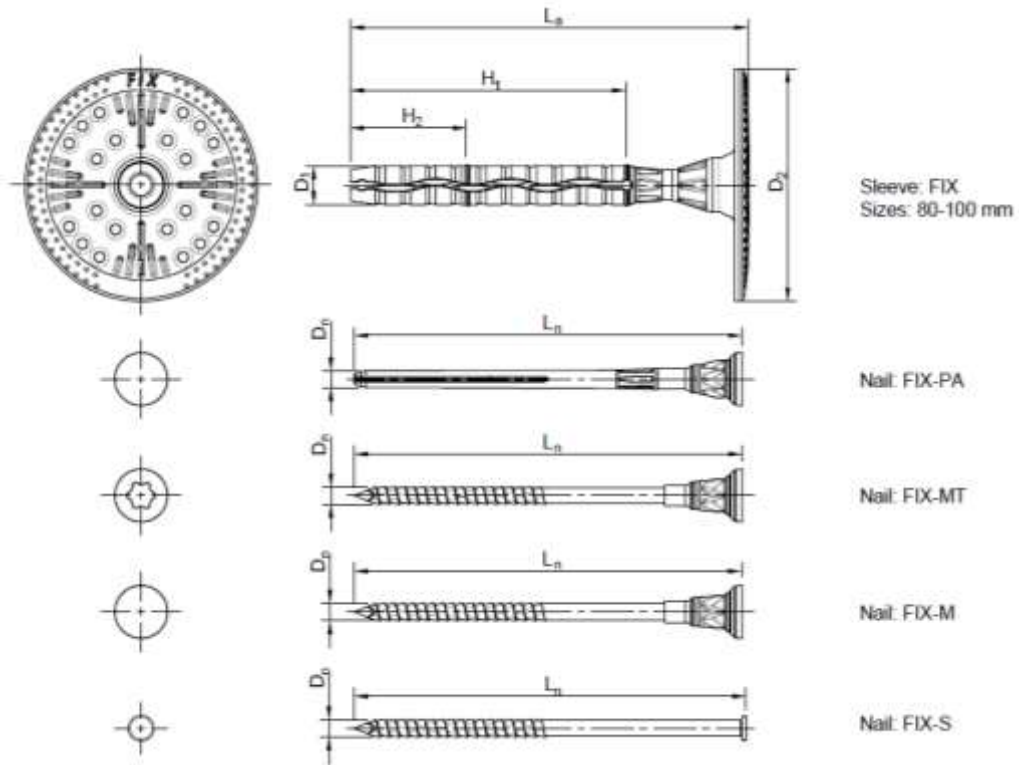
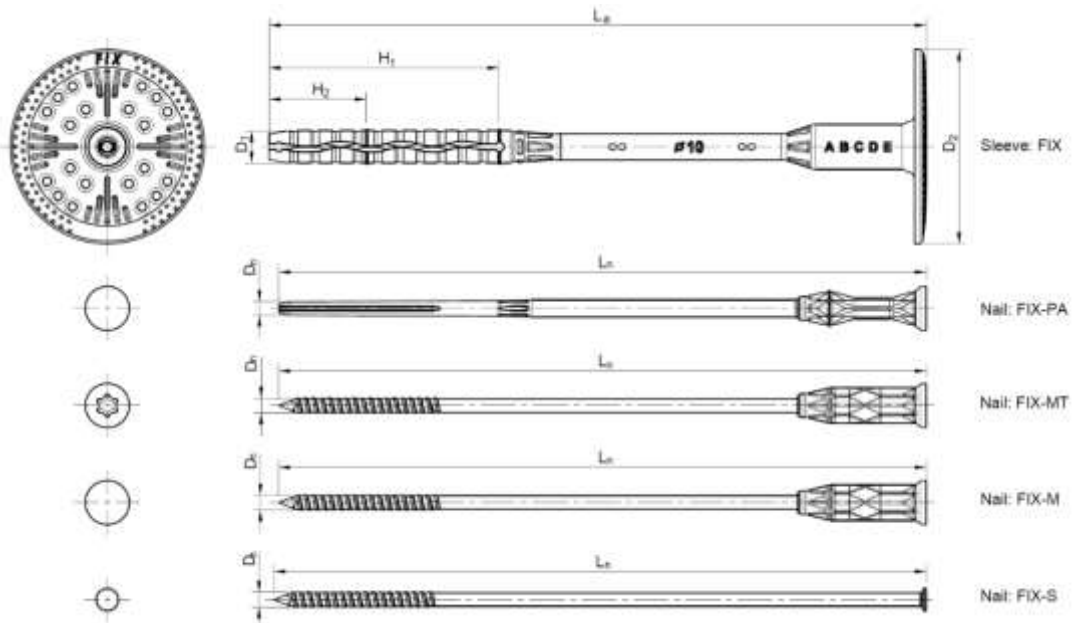
FIX-PA, FIX-S, FIX-M and FIX-MT with $L_a = 80 - 100$ mm

FIX-PA, FIX-S, FIX-M and FIX-MT with $L_a = 120 - 560$ mm

FIX-PA, FIX-S, FIX-M, FIX-MT and FIX-W
Product description

 Marking of the anchor sleeve and expansion element
of FIX-PA, FIX-S, FIX-M and FIX-MT anchors

Annex A3
of European
Technical Assessment
ETA-24/1085

Table A1: FIX-PA, FIX-S, FIX-M and FIX-MT dimensions [mm]

Anchor type	Anchor sleeve						Expansion pin	
	$D_1 \pm 0,1$	$L_a \pm 2$	$D_2 \pm 1,5$	h_{ef}	H_1	H_2	$D_n \pm 0,1$	$L_n \pm 2$
FIX-PA	10	80 - 560	60	30 / 70	70	30	5,3	80 - 560
FIX-S	10	80 - 560	60	30 / 70			4,4	80 - 560
FIX-M	10	80 - 560	60	30 / 70			4,4	80 - 560
FIX-MT	10	80 - 560	60	30 / 70			4,8	80 - 560

Determination of maximum thickness of insulation material:

For surface assembly: $h_d = L_a - t_{tol} - h_{ef}$

For countersunk assembly: $h_d = L_a - t_{tol} - h_{ef} + 20 \text{ mm}$

FIX-PA, FIX-S, FIX-M, FIX-MT and FIX-W

Product description

Dimensions of the anchor sleeve and expansion element of FIX-PA, FIX-S, FIX-M and FIX-MT anchors

Annex A4
of European
Technical Assessment
ETA-24/1085

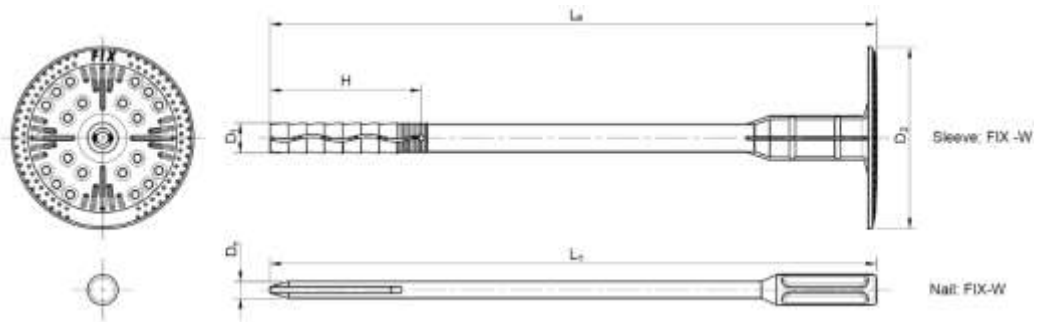
Table A2: FIX-W anchor dimensions [mm]

Anchor type	Anchor sleeve				Expansion pin	
	$D_1 \pm 0,1$	$L_a \pm 2$	$D_2 \pm 1,5$	$h_{ef} = H$	$D_n \pm 0,1$	$L_n \pm 2$
FIX-W	10	100 - 260	60	50	5,5	100 - 260

Determination of maximum thickness of insulation material:

For surface assembly: $h_d = L_a - t_{tol} - h_{ef}$

For countersunk assembly: $h_d = L_a - t_{tol} - h_{ef} + 20 \text{ mm}$

FIX-PA, FIX-S, FIX-M, FIX-MT and FIX-W

Product description

Marking and dimensions of the anchor sleeve and expansion element of FIX-W anchors

Annex A5
of European
Technical Assessment
ETA-24/1085

Table A3: Materials

Designation		Material
Anchor sleeve		Virgin plastic: polypropylene PP, natural / white, grey, orange or blue
Expansion pin	FIX-PA	Virgin plastic: polyamide PA6 reinforced with glass fibre GF30, black or natural
	FIX-M, FIX-MT	Carbon steel, electroplated $\geq 5 \mu\text{m}$ according to EN ISO 4042, covered with polyamide PA6, natural / white, black, yellow, blue, red, green
	FIX-S	Carbon steel, electroplated $\geq 5 \mu\text{m}$ according to EN ISO 4042
	FIX-W	Virgin plastic: polypropylene PP, natural / white, grey, orange or blue

FIX-PA, FIX-S, FIX-M, FIX-MT and FIX-W

Product description
Materials

Annex A6
of European
Technical Assessment
ETA-24/1085

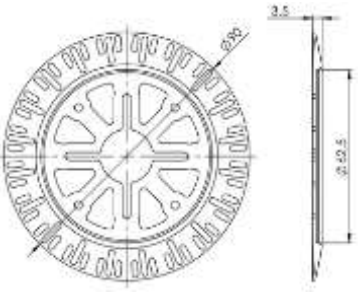
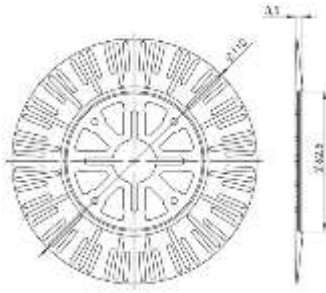
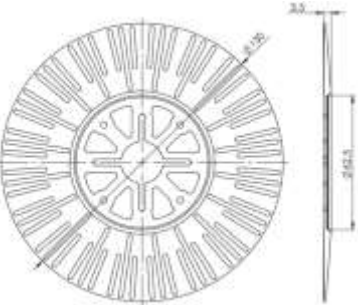
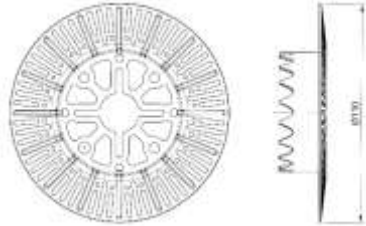
 <p>TDW 90</p>		 <p>TDW 110</p>	
 <p>TDW 130</p>		 <p>TDW 110 G</p>	
Table A4: Additional plates TDW 90, TDW 110, TDW 130 and TDW 110 G			
Plate type	Outer diameter [mm]	Material	
TDW 90	90	Polyamide PA6 reinforced with glass fibre GF30 (natural or grey) or polypropylene PP (natural or grey)	
TDW 110	110		
TDW 130	130		
TDW 110 G	110		
FIX-PA, FIX-S, FIX-M, FIX-MT and FIX-W		Annex A7 of European Technical Assessment ETA-24/1085	
Product description Additional plates TDW 90, TDW 110, TDW 130 and TDW 110 G			

Cutters for countersunk assembly:

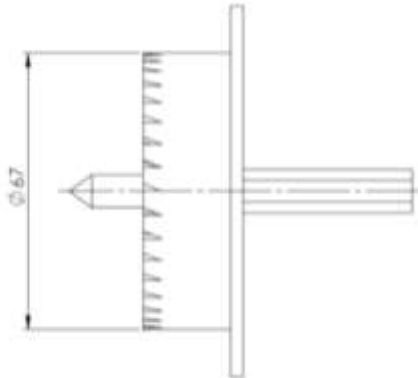

ZP-FS

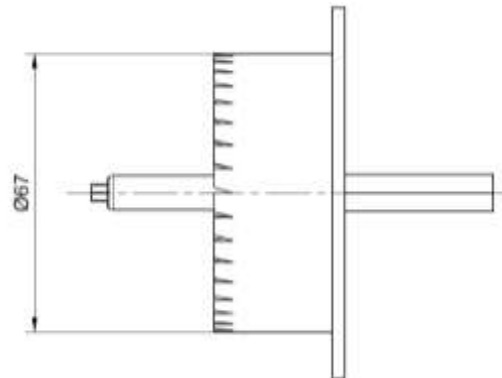

ZP-FT

Insulation cap:

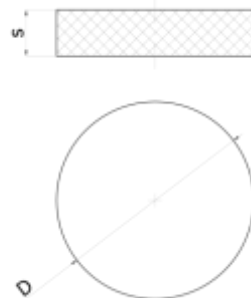

Table A5: Insulation cap

Thickness, s [mm]	Diameter, D [mm]	Material
16,5	67	expanded polystyrene (EPS) – white or grey
20		mineral wool (MW)

FIX-PA, FIX-S, FIX-M, FIX-MT and FIX-W

Product description
Cutters ZP-FS and ZP-FT for countersunk assembly and insulation cap

Annex A8
of European
Technical Assessment
ETA-24/1085

Specification of intended use**Anchorage subject to:**

- Wind suction loads.

Note: The anchor shall not be used for the transmission of dead loads of the external thermal insulation composite system (ETICS).

Base materials:

- Normal weight concrete (base material group A), according to Annex C1.
- Solid masonry (base material group B), according to Annex C1.
- Hollow or perforated masonry (base material group C), according to Annex C1.
- Lightweight aggregate concrete (base material group D), according to Annex C1.
- Autoclaved aerated concrete (base material group E), according to Annex C1.
- For other base materials of the base material groups A, B, C, D or E the characteristic resistance of the anchor may be determined by job site tests according to EOTA Technical Report TR 051, edition April 2018.

Temperature range:

- 0°C to +40°C (max. short term temperature +40°C and max. long term temperature +24°C).

Design:

- The anchorages are designed under the responsibility of an engineer experienced in anchorages and masonry work with the partial safety factors $\gamma_M = 2,0$ and $\gamma_F = 1,5$, if there are no other national regulations.
- Verifiable calculation notes and drawings with anchor positions are prepared taking into account of the loads to be anchored.
- Fasteners are only to be used for multiple fixings of external thermal insulation composite system (ETICS), according to EAD 330196-01-0604.

Installation:

- Hole shall be drilled by the drill modes according to Annex C1.
- Anchor installation shall be carried out by appropriately qualified personnel and under the supervision of the person responsible for technical matters of the site.
- Installation shall be executed in temperature from 0°C to +40°C.
- Exposure to UV due to solar radiation of the anchor not protected by rendering shall not exceed 6 weeks.

FIX-PA, FIX-S, FIX-M, FIX-MT and FIX-W**Intended use
Specifications****Annex B1
of European
Technical Assessment
ETA-24/1085**

Table B1: Installation characteristics for FIX-PA, FIX-S, FIX-M and FIX-MT

Anchor type		FIX-PA, FIX-S, FIX-M and FIX-MT	
Effective anchorage depth	$h_{ef} = h_{nom}$ [mm]	≥ 30	≥ 70
Drill hole diameter	d_o [mm]	10,00	
Cutting diameter of drill bit	d_{cut} [mm]	$\leq 10,45$	
Depth of drill hole	h_1 [mm]	≥ 40	≥ 80

Table B2: Installation characteristics for FIX-W

Anchor type		FIX-W
Effective anchorage depth	$h_{ef} = h_{nom}$ [mm]	≥ 50
Drill hole diameter	d_o [mm]	10,00
Cutting diameter of drill bit	d_{cut} [mm]	$\leq 10,45$
Depth of drill hole	h_1 [mm]	≥ 60

Table B3: Minimum thickness of base material, spacing and edge distance

Anchor type		FIX-PA, FIX-S, FIX-M, FIX-MT and FIX-W
Minimum thickness of base material	h [mm]	100
Minimum spacing	s_{min} [mm]	100
Minimum edge distance	c_{min} [mm]	100

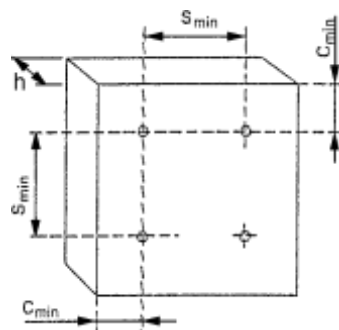







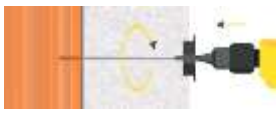

FIX-PA, FIX-S, FIX-M, FIX-MT and FIX-W

Intended use
Installation characteristics, minimum thickness
of base material, spacing and edge distance

Annex B2
of European
Technical Assessment
ETA-24/1085

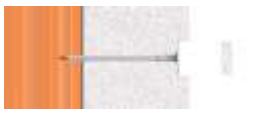
Table B4: Installation instruction of FIX-PA, FIX-S, FIX-M and FIX-W anchor – surface and countersunk assembly





Surface assembly:		Countersunk assembly with ZP-FS cutter:	
	1. Drill the hole perpendicular to the substrate surface. Clean the drill hole.		1. Drill the hole perpendicular to the substrate surface. Clean the drill hole.
	2. Place an anchor sleeve in the drill hole. The bottom side of the plate must be flush with the ETICS.		2. Drill a slot for countersunk installation using the drill with the ZP-FS cutter.
	3. Drive in a specific nail using the hammer.		3. Place an anchor sleeve in the drill hole. The bottom side of the plate must be flush with the ETICS.
	4. Assembled anchor.		4. Drive in a specific nail using the hammer.
			5. Install the insulation cover.
			6. Assembled anchor.

FIX-PA, FIX-S, FIX-M, FIX-MT and FIX-W
Intended use

Installation instruction of FIX-PA, FIX-S, FIX-M and FIX-W anchors – surface and countersunk assembly

Annex B3
 of European
 Technical Assessment
 ETA-24/1085

Table B5: Installation instruction of FIX-MT anchor – surface assembly







Surface assembly:	
	1. Drill the hole perpendicular to the substrate surface. Clean the drill hole.
	2. Place an anchor sleeve in the drill hole. The bottom side of the plate must be flush with the ETICS.
	3. Drive in a specific nail using the screwdriver or the hammer.
	4. Assembled anchor.

FIX-PA, FIX-S, FIX-M, FIX-MT and FIX-W

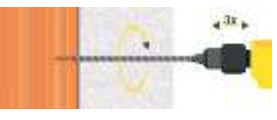
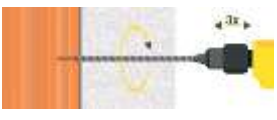
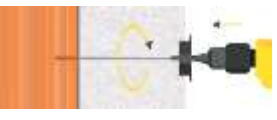
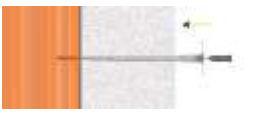
Intended use
Installation instruction of FIX-MT anchor – surface assembly

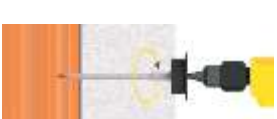
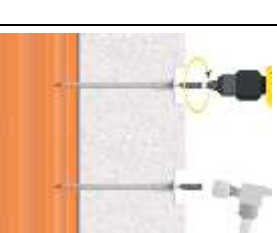
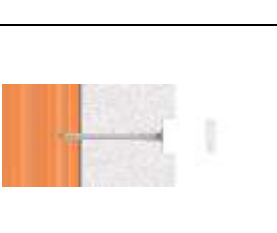
Annex B4
of European
Technical Assessment
ETA-24/1085

Table B6: Installation instruction of FIX-MT anchor – countersunk assembly



Countersunk assembly with ZP-FS cutter:		Countersunk assembly with ZP-FT cutter:	
	1. Drill the hole perpendicular to the substrate surface. Clean the drill hole.		1. Drill the hole perpendicular to the substrate surface. Clean the drill hole.
	2. Drill a slot for countersunk installation with the ZP-FS cutter.		2. Place an anchor sleeve in the drill hole. The bottom side of the plate must be flush with the ETICS.
	3. Place an anchor sleeve in the drill hole. The bottom side of the plate must be flush with the ETICS.		3. Drive in a specific nail using the screwdriver with the ZP-FT.
	4. Drive in a specific nail using the screwdriver or the hammer.		4. Install the insulation cover.
	5. Install the insulation cover.		5. Assembled anchor.
	6. Assembled anchor.		

FIX-PA, FIX-S, FIX-M, FIX-MT and FIX-W

Intended use
Installation instruction of FIX-MT anchor – countersunk assembly

Annex B5
of European
Technical Assessment
ETA-24/1085

Table C1.1: Characteristic resistance under tension loads N_{Rk} in concrete and in masonry for single FIX-PA anchor

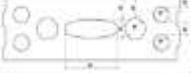
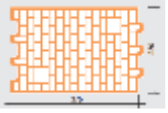
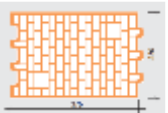

Base material group	Base material	Bulk density [kg/dm ³]	Compressive strength [N/mm ²]	Referring standard	N_{Rk} [kN]		Drill method
					$h_{ef} = 30$ mm	$h_{ef} = 70$ mm	
A	Concrete C12/15			EN 206-1	0,55	1,30	hammer
	Concrete C16/20 – C50/60			EN 206-1	0,80	1,50	hammer
	Thin concrete members C16/20 – C50/60			EN 206-1	0,80	1,50	hammer
B	Clay brick MZ 	$\geq 1,80$	$\geq 15,0$	EN 771-1	0,80	1,50	hammer
	Calcium silicate brick KS 	$\geq 1,80$	$\geq 15,0$	EN 771-2	0,80	1,50	hammer
C	Calcium silicate hollow block KSL  $a^{1)} = 40$ mm	$\geq 1,60$	$\geq 12,0$	EN 771-2	0,70	1,50	hammer
	Vertically perforated clay bricks Porotherm 25  $a^{1)} = 12$ mm	$\geq 0,80$	$\geq 15,0$	EN 771-1	0,50	1,00	rotary
	Vertically perforated clay bricks Porotherm 25  $a^{1)} = 17$ mm	$\geq 0,80$	$\geq 15,0$	EN 771-1	0,55	1,20	rotary
1) Minimum values "a". For elements with lower value of "a" the load tests on the construction site are required							

FIX-PA, FIX-S, FIX-M, FIX-MT and FIX-W

Performances
Characteristic resistance

Annex C1
of European
Technical Assessment
ETA-24/1085

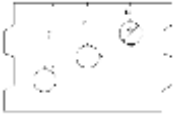
Table C1.2: Characteristic resistance under tension loads N_{Rk} in concrete and in masonry for single FIX-PA anchor

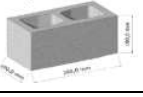
Base material group	Base material	Bulk density [kg/dm ³]	Compressive strength [N/mm ²]	Referring standard	N_{Rk} [kN]		Drill method
					$h_{ef} = 30$ mm	$h_{ef} = 70$ mm	
C	Lightweight concrete hollow block HBL $a^{1)} = 33$ mm 	$\geq 0,80$	$\geq 2,0$	EN 771-3	0,60	1,20	rotary
	Lightweight concrete hollow block Tekno Amerblok PK17,8 $a^{1)} = 30$ mm 	$\geq 1,50$	$\geq 25,0$	EN 771-3	0,80	1,50	rotary
	Lightweight concrete hollow block Tekno Amerblok PK19 $a^{1)} = 30$ mm 	$\geq 1,10$	$\geq 20,0$	EN 771-3	0,80	1,50	rotary
D	Lightweight concrete block LAC	$\geq 0,88$	$\geq 5,0$	EN 771-3	0,60	1,20	rotary
E	Autoclaved aerated concrete block AAC2	$\geq 0,35$	$\geq 2,0$	EN 771-4	0,60	1,20	rotary
	Autoclaved aerated concrete block AAC7	$\geq 0,65$	$\geq 5,0$	EN 771-4	0,75	1,50	rotary

 Partial safety factor for anchor resistance, $\gamma_M^{2)}$

2,0





¹⁾ Minimum values "a". For elements with lower value of "a" the load tests on the construction site are required

²⁾ Valid in absence of other national regulations

FIX-PA, FIX-S, FIX-M, FIX-MT and FIX-W
Performances
 Characteristic resistance

Annex C1
 of European
 Technical Assessment
 ETA-24/1085

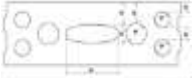
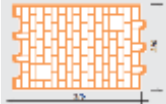
Table C1.3: Characteristic resistance under tension loads N_{Rk} in concrete and in masonry for single FIX-S and FIX-M anchor

Base material group	Base material	Bulk density [kg/dm ³]	Compressive strength [N/mm ²]	Referring standard	N_{Rk} [kN]		Drill method
					$h_{ef} = 30$ mm	$h_{ef} = 70$ mm	
A	Concrete C12/15			EN 206-1	0,70	1,30	hammer
	Concrete C16/20 – C50/60			EN 206-1	1,00	1,50	hammer
	Thin concrete members C16/20 – C50/60			EN 206-1	1,00	1,50	hammer
B	Clay brick MZ 	$\geq 1,80$	$\geq 15,0$	EN 771-1	1,00	1,50	hammer
	Calcium silicate brick KS 	$\geq 1,80$	$\geq 15,0$	EN 771-2	1,00	1,50	hammer
C	Calcium silicate hollow block KSL  $a^{1)} = 40$ mm	$\geq 1,60$	$\geq 12,0$	EN 771-2	1,00	1,50	hammer
	Vertically perforated clay bricks Porothersm 25  $a^{1)} = 12$ mm	$\geq 0,80$	$\geq 15,0$	EN 771-1	0,50	0,60	rotary
	Vertically perforated clay bricks Porothersm 25  $a^{1)} = 17$ mm	$\geq 0,80$	$\geq 15,0$	EN 771-1	0,55	0,80	rotary

¹⁾ Minimum values "a". For elements with lower value of "a" the load tests on the construction site are required

FIX-PA, FIX-S, FIX-M, FIX-MT and FIX-W

Performances
Characteristic resistance

Annex C1
of European
Technical Assessment
ETA-24/1085

Table C1.4: Characteristic resistance under tension loads N_{Rk} in concrete and in masonry for single FIX-S and FIX-M anchor







Base material group	Base material	Bulk density [kg/dm ³]	Compressive strength [N/mm ²]	Referring standard	N_{Rk} [kN]		Drill method
					$h_{ef} = 30$ mm	$h_{ef} = 70$ mm	
C	Lightweight concrete hollow block HBL $a^{1)} = 33$ mm 	$\geq 0,80$	$\geq 2,0$	EN 771-3	0,60	0,90	rotary
	Lightweight concrete hollow block Tekno Amerblok PK17,8 $a^{1)} = 30$ mm 	$\geq 1,50$	$\geq 25,0$	EN 771-3	1,00	1,50	rotary
	Lightweight concrete hollow block Tekno Amerblok PK19 $a^{1)} = 30$ mm 	$\geq 1,10$	$\geq 20,0$	EN 771-3	1,00	1,50	rotary
D	Lightweight concrete block LAC	$\geq 0,88$	$\geq 5,0$	EN 771-3	0,60	0,90	rotary
E	Autoclaved aerated concrete block AAC2	$\geq 0,35$	$\geq 2,0$	EN 771-4	0,60	0,90	rotary
	Autoclaved aerated concrete block AAC7	$\geq 0,65$	$\geq 5,0$	EN 771-4	0,70	1,20	rotary
Partial safety factor for anchor resistance, $\gamma_M^{2)}$		2,0					
¹⁾ Minimum values "a". For elements with lower value of "a" the load tests on the construction site are required ²⁾ Valid in absence of other national regulations							
FIX-PA, FIX-S, FIX-M, FIX-MT and FIX-W					Annex C1 of European Technical Assessment ETA-24/1085		
Performances Characteristic resistance							

Table C1.5: Characteristic resistance under tension loads N_{Rk} in concrete and in masonry for single FIX-MT anchor

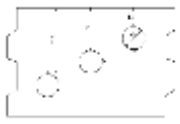

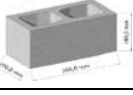
Base material group	Base material	Bulk density [kg/dm ³]	Compressive strength [N/mm ²]	Referring standard	N_{Rk} [kN]		Drill method
					$h_{ef} = 30$ mm	$h_{ef} = 70$ mm	
A	Concrete C12/15			EN 206-1	0,70	1,40	hammer
	Concrete C16/20 – C50/60			EN 206-1	1,00	1,50	hammer
	Thin concrete members C16/20 – C50/60			EN 206-1	1,00	1,50	hammer
B	Clay brick MZ 	≥ 1,80	≥ 15,0	EN 771-1	1,00	1,50	hammer
	Calcium silicate brick KS 	≥ 1,80	≥ 15,0	EN 771-2	1,00	1,50	hammer
C	Calcium silicate hollow block KSL  $a^{1)} = 40$ mm	≥ 1,60	≥ 12,0	EN 771-2	1,00	1,50	hammer
	Vertically perforated clay bricks Porotherm 25  $a^{1)} = 12$ mm	≥ 0,80	≥ 15,0	EN 771-1	0,50	0,60	rotary
	Vertically perforated clay bricks Porotherm 25  $a^{1)} = 17$ mm	≥ 0,80	≥ 15,0	EN 771-1	0,55	0,80	rotary
¹⁾ Minimum values "a". For elements with lower value of "a" the load tests on the construction site are required							

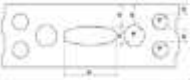
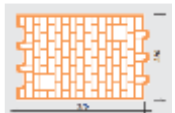
FIX-PA, FIX-S, FIX-M, FIX-MT and FIX-W

Performances
Characteristic resistance

Annex C1
of European
Technical Assessment
ETA-24/1085

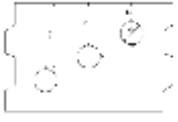
Table C1.6: Characteristic resistance under tension loads N_{Rk} in concrete and in masonry for single FIX-MT anchor

Base material group	Base material	Bulk density [kg/dm ³]	Compressive strength [N/mm ²]	Referring standard	N_{Rk} [kN]		Drill method
					$h_{ef} = 30$ mm	$h_{ef} = 70$ mm	
C	Lightweight concrete hollow block HBL $a^{1)} = 33$ mm 	$\geq 0,80$	$\geq 2,0$	EN 771-3	0,60	0,90	rotary
	Lightweight concrete hollow block Tekno Amerblok PK17,8 $a^{1)} = 30$ mm 	$\geq 1,50$	$\geq 25,0$	EN 771-3	1,00	1,50	rotary
	Lightweight concrete hollow block Tekno Amerblok PK19 $a^{1)} = 30$ mm 	$\geq 1,10$	$\geq 20,0$	EN 771-3	1,00	1,50	rotary
D	Lightweight concrete block LAC	$\geq 0,88$	$\geq 5,0$	EN 771-3	0,60	0,90	rotary
E	Autoclaved aerated concrete block AAC2	$\geq 0,35$	$\geq 2,0$	EN 771-4	0,60	1,20	rotary
	Autoclaved aerated concrete block AAC7	$\geq 0,65$	$\geq 5,0$	EN 771-4	0,70	1,40	rotary

 Partial safety factor for anchor resistance, $\gamma_M^{2)}$

2,0





¹⁾ Minimum values "a". For elements with lower value of "a" the load tests on the construction site are required

²⁾ Valid in absence of other national regulations

FIX-PA, FIX-S, FIX-M, FIX-MT and FIX-W
Performances
 Characteristic resistance

Annex C1
 of European
 Technical Assessment
 ETA-24/1085

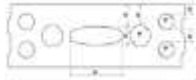
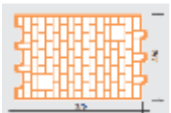
Table C1.7: Characteristic resistance under tension loads N_{Rk} in concrete and in masonry for single FIX-W anchor

Base material group	Base material	Bulk density [kg/dm ³]	Compressive strength [N/mm ²]	Referring standard	N_{Rk} [kN]	Drill method
					$h_{ef} = 50$ mm	
A	Concrete C12/15			EN 206-1	0,70	hammer
	Concrete C16/20 – C50/60			EN 206-1	1,00	hammer
	Thin concrete members C16/20 – C50/60			EN 206-1	1,00	hammer
B	Clay brick MZ 	≥ 1,80	≥ 15,0	EN 771-1	0,80	hammer
	Calcium silicate brick KS 	≥ 1,80	≥ 15,0	EN 771-2	0,80	hammer
C	Calcium silicate hollow block KSL  $a^1 = 40$ mm	≥ 1,60	≥ 12,0	EN 771-2	0,70	hammer
	Vertically perforated clay bricks Porotherm 25  $a^1 = 12$ mm	≥ 0,80	≥ 15,0	EN 771-1	0,40	rotary
	Vertically perforated clay bricks Porotherm 25  $a^1 = 17$ mm	≥ 0,80	≥ 15,0	EN 771-1	0,50	rotary



¹⁾ Minimum values "a". For elements with lower value of "a" the load tests on the construction site are required

FIX-PA, FIX-S, FIX-M, FIX-MT and FIX-W

Performances
Characteristic resistance

Annex C1
of European
Technical Assessment
ETA-24/1085

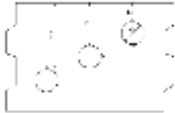
Table C1.8: Characteristic resistance under tension loads N_{Rk} in concrete and in masonry for single FIX-W anchor

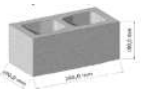
Base material group	Base material	Bulk density [kg/dm ³]	Compressive strength [N/mm ²]	Referring standard	N _{Rk} [kN]	Drill method
					h _{ef} = 50 mm	
C	Lightweight concrete hollow block HBL a ¹⁾ = 33 mm 	≥ 0,80	≥ 2,0	EN 771-3	0,50	rotary
	Lightweight concrete hollow block Tekno Amerblok PK17,8 a ¹⁾ = 30 mm 	≥ 1,50	≥ 25,0	EN 771-3	1,00	rotary
	Lightweight concrete hollow block Tekno Amerblok PK19 a ¹⁾ = 30 mm 	≥ 1,10	≥ 20,0	EN 771-3	1,00	rotary
D	Lightweight concrete block LAC	≥ 0,88	≥ 5,0	EN 771-3	0,50	rotary
E	Autoclaved aerated concrete block AAC2	≥ 0,35	≥ 2,0	EN 771-4	0,50	rotary
	Autoclaved aerated concrete block AAC7	≥ 0,65	≥ 5,0	EN 771-4	0,60	rotary

 Partial safety factor for anchor resistance, $\gamma_M^{2)}$

2,0

¹⁾ Minimum values "a". For elements with lower value of "a" the load tests on the construction site are required

²⁾ Valid in absence of other national regulations

FIX-PA, FIX-S, FIX-M, FIX-MT and FIX-W
Performances
 Characteristic resistance

Annex C1
 of European
 Technical Assessment
 ETA-24/1085

Table C2.1: Point thermal transmittance according to EOTA Technical Report TR 025

Anchor type	Insulation thickness H_D [mm]	Point thermal transmittance χ [W/K]
Surface installation		
FIX-PA and FIX-W	40	0,000
	150	0,000
	530	0,000
FIX-M and FIX-MT	40	0,002
	150	0,002
	530	0,001
FIX-S	40	0,005
	150	0,003
	530	0,002
Countersunk installation		
FIX-PA and FIX-W	40	0,000
	150	0,000
	530	0,000
FIX-M and FIX-MT	40	0,001
	150	0,002
	530	0,001
FIX-S	40	0,001
	150	0,002
	530	0,001

Table C2.2: Plate stiffness according to EOTA Technical Report TR 026



Anchor type	Diameter of the anchor plate d_{plate} [mm]	Load resistance of the anchor plate $N_{u,m}$ [kN]	Plate stiffness $N_{0,m}$ [kN/mm]
FIX-PA, FIX-S, FIX-M and FIX-MT	60	2,60	1,0
FIX-W	60	1,57	0,5

FIX-PA, FIX-S, FIX-M, FIX-MT and FIX-W

Performances
Point thermal transmittance and plate stiffness

Annex C2
of European
Technical Assessment
ETA-24/1085

Table C3.1: Displacements for FIX-PA

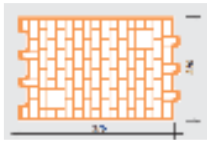
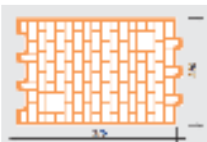

Base material group	Base material	Bulk density [kg/dm ³]	Compressive strength [N/mm ²]	$\frac{N_{Rk}}{3}$ [kN]		$\delta\left(\frac{N_{Rk}}{3}\right)$ [mm]	
				$h_{ef} = 30$ mm	$h_{ef} = 70$ mm	$h_{ef} = 30$ mm	$h_{ef} = 70$ mm
A	Concrete C12/15	–	–	0,18	0,43	0,10	0,19
	Concrete C16/20 – C50/60	–	–	0,27	0,50	0,14	0,20
	Thin concrete members C16/20 – C50/60	–	–	0,27	0,50	0,14	0,20
B	Clay brick MZ 	≥ 1,80	≥ 15,0	0,27	0,50	0,13	0,22
	Calcium silicate brick KS 	≥ 1,80	≥ 15,0	0,27	0,50	0,13	0,22
C	Calcium silicate hollow block KSL  a ¹⁾ = 40 mm	≥ 1,60	≥ 12,0	0,23	0,50	0,13	0,22
	Vertically perforated porosited block Porotherm 25  a ¹⁾ = 12 mm	≥ 0,80	≥ 15,0	0,17	0,33	0,13	0,22
	Vertically perforated porosited block Porotherm 25  a ¹⁾ = 17 mm	≥ 0,80	≥ 15,0	0,18	0,40	0,13	0,22

¹⁾ Minimum values "a". For elements with lower value of "a" the load tests on the construction site are required

FIX-PA, FIX-S, FIX-M, FIX-MT and FIX-W
Performances
Displacements

Annex C3
of European
Technical Assessment
ETA-24/1085

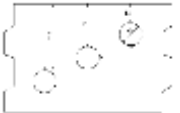
Table C3.2: Displacements for FIX-PA

Base material group	Base material	Bulk density [kg/dm ³]	Compressive strength [N/mm ²]	$\frac{N_{Rk}}{3}$ [kN]		$\delta\left(\frac{N_{Rk}}{3}\right)$ [mm]	
				$h_{ef} = 30$ mm	$h_{ef} = 70$ mm	$h_{ef} = 30$ mm	$h_{ef} = 70$ mm
C	Lightweight concrete hollow block HBL $a^{1)} = 33$ mm 	$\geq 0,80$	$\geq 2,0$	0,20	040	0,13	0,22
	Lightweight concrete hollow block Tekno Amerblok PK17,8 $a^{1)} = 30$ mm 	$\geq 1,50$	$\geq 25,0$	0,27	0,50	0,14	0,20
	Lightweight concrete hollow block Tekno Amerblok PK19 $a^{1)} = 30$ mm 	$\geq 1,10$	$\geq 20,0$	0,27	0,50	0,14	0,20
D	Lightweight concrete block LAC	$\geq 0,88$	$\geq 5,0$	0,20	0,40	0,09	0,33
E	Autoclaved aerated concrete block AAC2	$\geq 0,35$	$\geq 2,0$	0,20	0,40	0,22	0,33
	Autoclaved aerated concrete block AAC7	$\geq 0,65$	$\geq 5,0$	0,25	0,50	0,22	0,15



¹⁾ Minimum values "a". For elements with lower value of "a" the load tests on the construction site are required

FIX-PA, FIX-S, FIX-M, FIX-MT and FIX-W

Performances
Displacements

Annex C3
of European
Technical Assessment
ETA-24/1085

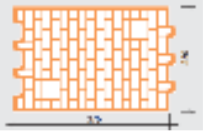
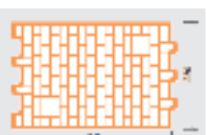
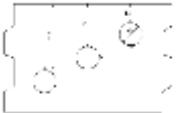

Table C3.3: Displacements for FIX-S and FIX-M

Base material group	Base material	Bulk density [kg/dm ³]	Compressive strength [N/mm ²]	$\frac{N_{Rk}}{3}$ [kN]		$\delta\left(\frac{N_{Rk}}{3}\right)$ [mm]	
				$h_{ef} = 30$ mm	$h_{ef} = 70$ mm	$h_{ef} = 30$ mm	$h_{ef} = 70$ mm
A	Concrete C12/15	–	–	0,23	0,43	0,10	0,19
	Concrete C16/20 – C50/60	–	–	0,33	0,50	0,15	0,22
	Thin concrete members C16/20 – C50/60	–	–	0,33	0,50	0,15	0,22
B	Clay brick MZ 	≥ 1,80	≥ 15,0	0,33	0,50	0,39	0,45
	Calcium silicate brick KS 	≥ 1,80	≥ 15,0	0,33	0,50	0,39	0,45
C	Calcium silicate hollow block KSL  a ¹⁾ = 40 mm	≥ 1,60	≥ 12,0	0,33	0,50	0,39	0,45
	Vertically perforated porous block Porotherm 25  a ¹⁾ = 12 mm	≥ 0,80	≥ 15,0	0,17	0,20	0,39	0,45
	Vertically perforated porous block Porotherm 25  a ¹⁾ = 17 mm	≥ 0,80	≥ 15,0	0,18	0,27	0,39	0,45

¹⁾ Minimum values “a”. For elements with lower value of “a” the load tests on the construction site are required

FIX-PA, FIX-S, FIX-M, FIX-MT and FIX-W
**Performances
Displacements**
**Annex C3
of European
Technical Assessment
ETA-24/1085**

Table C3.4: Displacements for FIX-S and FIX-M

Base material group	Base material	Bulk density [kg/dm ³]	Compressive strength [N/mm ²]	$\frac{N_{Rk}}{3}$ [kN]		$\delta\left(\frac{N_{Rk}}{3}\right)$ [mm]	
				$h_{ef} = 30$ mm	$h_{ef} = 70$ mm	$h_{ef} = 30$ mm	$h_{ef} = 70$ mm
C	Lightweight concrete hollow block HBL $a^{1)} = 33$ mm 	$\geq 0,80$	$\geq 2,0$	0,20	0,30	0,39	0,45
	Lightweight concrete hollow block Tekno Amerblok PK17,8 $a^{1)} = 30$ mm 	$\geq 1,50$	$\geq 25,0$	0,33	0,50	0,15	0,22
	Lightweight concrete hollow block Tekno Amerblok PK19 $a^{1)} = 30$ mm 	$\geq 1,10$	$\geq 20,0$	0,33	0,50	0,15	0,22
D	Lightweight concrete block LAC	$\geq 0,88$	$\geq 5,0$	0,20	0,30	0,07	0,11
E	Autoclaved aerated concrete block AAC2	$\geq 0,35$	$\geq 2,0$	0,20	0,40	0,12	0,17
	Autoclaved aerated concrete block AAC7	$\geq 0,65$	$\geq 5,0$	0,23	0,30	0,12	0,17



¹⁾ Minimum values "a". For elements with lower value of "a" the load tests on the construction site are required

FIX-PA, FIX-S, FIX-M, FIX-MT and FIX-W

Performances
Displacements

Annex C3
of European
Technical Assessment
ETA-24/1085

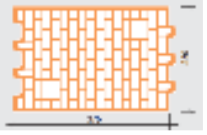
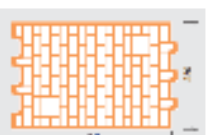
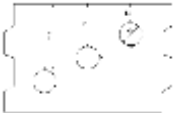

Table C3.5: Displacements for FIX-MT

Base material group	Base material	Bulk density [kg/dm ³]	Compressive strength [N/mm ²]	$\frac{N_{Rk}}{3}$ [kN]		$\delta\left(\frac{N_{Rk}}{3}\right)$ [mm]	
				$h_{ef} = 30$ mm	$h_{ef} = 70$ mm	$h_{ef} = 30$ mm	$h_{ef} = 70$ mm
A	Concrete C12/15	–	–	0,23	0,47	0,10	0,21
	Concrete C16/20 – C50/60	–	–	0,33	0,50	0,15	0,22
	Thin concrete members C16/20 – C50/60	–	–	0,33	0,50	0,15	0,22
B	Clay brick MZ 	≥ 1,80	≥ 15,0	0,33	0,50	0,39	0,45
	Calcium silicate brick KS 	≥ 1,80	≥ 15,0	0,33	0,50	0,39	0,45
C	Calcium silicate hollow block KSL  a ¹⁾ = 40 mm	≥ 1,60	≥ 12,0	0,33	0,50	0,39	0,45
	Vertically perforated porous block Porotherm 25  a ¹⁾ = 12 mm	≥ 0,80	≥ 15,0	0,17	0,20	0,39	0,45
	Vertically perforated porous block Porotherm 25  a ¹⁾ = 17 mm	≥ 0,80	≥ 15,0	0,18	0,27	0,39	0,45

¹⁾ Minimum values “a”. For elements with lower value of “a” the load tests on the construction site are required

FIX-PA, FIX-S, FIX-M, FIX-MT and FIX-W
**Performances
Displacements**
**Annex C3
of European
Technical Assessment
ETA-24/1085**

Table C3.6: Displacements for FIX-MT

Base material group	Base material	Bulk density [kg/dm ³]	Compressive strength [N/mm ²]	$\frac{N_{Rk}}{3}$ [kN]		$\delta\left(\frac{N_{Rk}}{3}\right)$ [mm]	
				$h_{ef} = 30$ mm	$h_{ef} = 70$ mm	$h_{ef} = 30$ mm	$h_{ef} = 70$ mm
C	Lightweight concrete hollow block HBL $a^{1)} = 33$ mm 	$\geq 0,80$	$\geq 2,0$	0,20	0,30	0,39	0,45
	Lightweight concrete hollow block Tekno Amerblok PK17,8 $a^{1)} = 30$ mm 	$\geq 1,50$	$\geq 25,0$	0,33	0,50	0,15	0,22
	Lightweight concrete hollow block Tekno Amerblok PK19 $a^{1)} = 30$ mm 	$\geq 1,10$	$\geq 20,0$	0,33	0,50	0,15	0,22
D	Lightweight concrete block LAC	$\geq 0,88$	$\geq 5,0$	0,20	0,30	0,07	0,11
E	Autoclaved aerated concrete block AAC2	$\geq 0,35$	$\geq 2,0$	0,20	0,40	0,12	0,21
	Autoclaved aerated concrete block AAC7	$\geq 0,65$	$\geq 5,0$	0,23	0,47	0,12	0,21



¹⁾ Minimum values "a". For elements with lower value of "a" the load tests on the construction site are required

FIX-PA, FIX-S, FIX-M, FIX-MT and FIX-W

Performances
Displacements

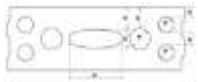
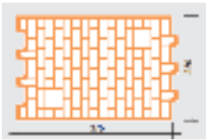
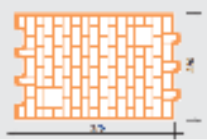

Annex C3
of European
Technical Assessment
ETA-24/1085

Table C3.7: Displacements for FIX-W

Base material group	Base material	Bulk density [kg/dm ³]	Compressive strength [N/mm ²]	$\frac{N_{Rk}}{3}$ [kN]	$\delta\left(\frac{N_{Rk}}{3}\right)$ [mm]
				$h_{ef} = 50$ mm	$h_{ef} = 50$ mm
A	Concrete C12/15	–	–	0,23	0,05
	Concrete C16/20 – C50/60	–	–	0,33	0,07
	Thin concrete members C16/20 – C50/60	–	–	0,33	0,07
B	Clay brick MZ 	≥ 1,80	≥ 15,0	0,27	0,06
	Calcium silicate brick KS 	≥ 1,80	≥ 15,0	0,27	0,06
C	Calcium silicate hollow block KSL  a ¹⁾ = 40 mm	≥ 1,60	≥ 12,0	0,23	0,06
	Vertically perforated porous block Porotherm 25  a ¹⁾ = 12 mm	≥ 0,80	≥ 15,0	0,13	0,06
	Vertically perforated porous block Porotherm 25  a ¹⁾ = 17 mm	≥ 0,80	≥ 15,0	0,17	0,06
¹⁾ Minimum values "a". For elements with lower value of "a" the load tests on the construction site are required					

FIX-PA, FIX-S, FIX-M, FIX-MT and FIX-W
**Performances
Displacements**
**Annex C3
of European
Technical Assessment
ETA-24/1085**

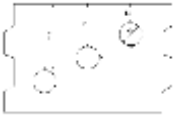
Table C3.8: Displacements for FIX-W

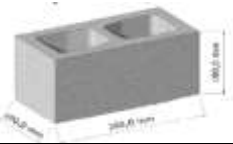
Base material group	Base material	Bulk density [kg/dm ³]	Compressive strength [N/mm ²]	$\frac{N_{Rk}}{3}$ [kN]	$\delta\left(\frac{N_{Rk}}{3}\right)$ [mm]
				$h_{ef} = 50$ mm	$h_{ef} = 50$ mm
C	Lightweight concrete hollow block HBL $a^{1)} = 33$ mm 	$\geq 0,80$	$\geq 2,0$	0,17	0,06
	Lightweight concrete hollow block Tekno Amerblok PK17,8 $a^{1)} = 30$ mm 	$\geq 1,50$	$\geq 25,0$	0,33	0,07
	Lightweight concrete hollow block Tekno Amerblok PK19 $a^{1)} = 30$ mm 	$\geq 1,10$	$\geq 20,0$	0,33	0,07
D	Lightweight concrete block LAC	$\geq 0,88$	$\geq 5,0$	0,17	0,07
E	Autoclaved aerated concrete block AAC2	$\geq 0,35$	$\geq 2,0$	0,17	0,07
	Autoclaved aerated concrete block AAC7	$\geq 0,65$	$\geq 5,0$	0,20	0,07
¹⁾ Minimum values "a". For elements with lower value of "a" the load tests on the construction site are required					

FIX-PA, FIX-S, FIX-M, FIX-MT and FIX-W

Performances
 Displacements

Annex C3
 of European
 Technical Assessment
 ETA-24/1085